

По вопросам продаж и поддержки обращайтесь:

Архангельск (8182)63-90-72	Краснодар (861)203-40-90	Рязань (4912)46-61-64
Астана (7172)727-132	Красноярск (391)204-63-61	Самара (846)206-03-16
Белгород (4722)40-23-64	Курск (4712)77-13-04	Санкт-Петербург (812)309-46-40
Брянск (4832)59-03-52	Липецк (4742)52-20-81	Саратов (845)249-38-78
Владивосток (423)249-28-31	Магнитогорск (3519)55-03-13	Смоленск (4812)29-41-54
Волгоград (844)278-03-48	Москва (495)268-04-70	Сочи (862)225-72-31
Вологда (8172)26-41-59	Мурманск (8152)59-64-93	Ставрополь (8652)20-65-13
Воронеж (473)204-51-73	Набережные Челны (8552)20-53-41	Тверь (4822)63-31-35
Екатеринбург (343)384-55-89	Нижний Новгород (831)429-08-12	Томск (3822)98-41-53
Иваново (4932)77-34-06	Новокузнецк (3843)20-46-81	Тула (4872)74-02-29
Ижевск (3412)26-03-58	Новосибирск (383)227-86-73	Тюмень (3452)66-21-18
Казань (843)206-01-48	Орел (4862)44-53-42	Ульяновск (8422)24-23-59
Калининград (4012)72-03-81	Оренбург (3532)37-68-04	Уфа (347)229-48-12
Калуга (4842)92-23-67	Пенза (8412)22-31-16	Челябинск (351)202-03-61
Кемерово (3842)65-04-62	Пермь (342)205-81-47	Череповец (8202)49-02-64
Киров (8332)68-02-04	Ростов-на-Дону (863)308-18-15	Ярославль (4852)69-52-93

Единый адрес: ctv@nt-rt.ru **Веб-сайт:** www.clilive.nt-rt.ru

Тепловой насос WSHN-XEE 82-802 Clivet



Water chiller

WSHN-XEE: reversible heat pump

WSH-XEE: cooling only

Water cooled

Indoor installation

Capacity from 38 to 328 kW



HYDRONIC

ELFOEnergy Ground Medium

ELFOEnergy Ground Medium is a water cooled heat pump for indoor installation, ideal for multi-family and commercial buildings.

The main features are:

- ▶ **HIGH SEASONALEFFICIENCY** - The combination of different size compressors allows to gain more control steps, to provide the energy actually required by the system, to reduce the consumption and to achieve the high seasonal efficiency. The unit reaches the Eurovent Class A heating and cooling for use with underfloor heating.
- ▶ **VERSION GROUND WATER OR GEOTHERMAL** - The use of heat exchangers for specific applications with ground water or geothermal closed loop maximize the energy efficiency.
- ▶ **ENERGY RECOVERY** - The partial or full recovery meets the demand of thermal loads and the production of hot water depending on the type of system.
- ▶ **PREASSEMBLED UNIT** - All major components are provided on the unit, ensuring maximum reliability and ease of installation.
- ▶ **MODULARITY AND MANAGEMENT OF MORE UNITS IN WATERFALL** - The compact construction with upflow water connections allows to combine multiple units in confined spaces, realizing a high power system. The control allows to coordinate up to 6 units managing automatically the operation with maximum efficiency.

functions and features

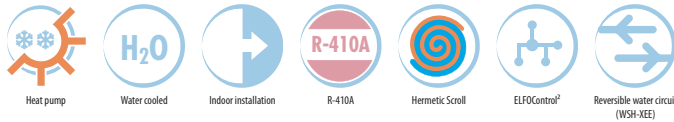

dimensions and clearances

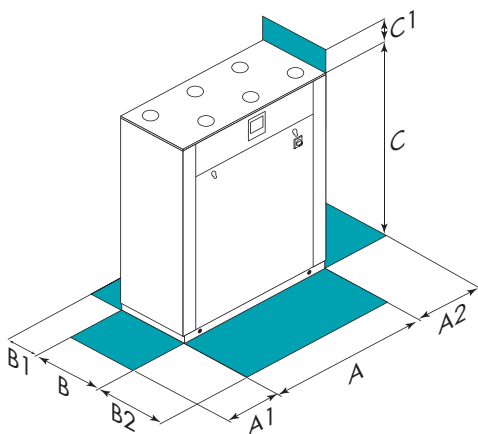

Size – WSHN-XEE	82	102	122	162	182	222	262	302	352	402	432	452	502	552	602	702	802
A - Length	mm	1200	1200	1200	1200	1200	1200	1200	1200	1966	1966	1966	1966	1966	1966	1966	1966
B - Width	mm	656	656	656	656	656	656	656	948	948	948	948	948	948	948	948	948
C - Height	(*) mm	1430	1430	1430	1430	1430	1430	1430	1620	1620	1620	1620	1620	1620	1620	1620	1620
A1	mm	300	300	300	300	300	300	300	300	300	300	300	300	300	300	300	300
A2	mm	300	300	300	300	300	300	300	300	300	300	300	300	300	300	300	300
B1	mm	800	800	800	800	800	800	800	800	800	800	800	800	800	800	800	800
B2	mm	100	100	100	100	100	100	100	100	100	100	100	100	100	100	100	100
C1	mm	300	300	300	300	300	300	300	200	200	200	200	200	200	200	200	200
Operating weight	kg	407	425	453	504	517	531	545	611	1011	1042	1169	1179	1193	1228	1258	1306

Size – WSH-XEE	82	102	122	162	182	222	262	302	352	402	432	452	502	552	602	702	802
A - Length	mm	1200	1200	1200	1200	1200	1200	1200	1200	1966	1966	1966	1966	1966	1966	1966	1966
B - Width	mm	656	656	656	656	656	656	656	948	948	948	948	948	948	948	948	948
C - Height	(*) mm	1430	1430	1430	1430	1430	1430	1430	1620	1620	1620	1620	1620	1620	1620	1620	1620
A1	mm	300	300	300	300	300	300	300	300	300	300	300	300	300	300	300	300
A2	mm	300	300	300	300	300	300	300	300	300	300	300	300	300	300	300	300
B1	mm	800	800	800	800	800	800	800	800	800	800	800	800	800	800	800	800
B2	mm	100	100	100	100	100	100	100	100	100	100	100	100	100	100	100	100
C1	mm	300	300	300	300	300	300	300	200	200	200	200	200	200	200	200	200
Operating weight	kg	407	425	453	504	517	531	545	611	1011	1042	1169	1179	1193	1228	1258	1306

CAUTION! For trouble-free operation of the unit it is essential to maintain the safety distances indicated by the green areas.

The above mentioned data are referred to standard units for the constructive configurations indicated. For all the other configurations, refer to the relative Data Sheet.

(*) The units with Hydronic Unit and/or valves mounted on board option are 1980 mm high.

versions and configurations

- ▶ **GEO** Version for Geothermal application
- ▶ **D** Partial energy recovery
- ▶ **R** Total energy recovery (WSHN-XEE only)

- ▶ **MOBMAG** Larger units

accessories

- ▶ **HYGU1** Utility side hydronic unit with 1 ON/OFF pump
- ▶ **HYGU2** Utility side hydronic unit with 2 ON/OFF pumps
- ▶ **HYGU1V** Utility side hydronic unit with 1 inverter pump
- ▶ **HYGU2V** Utility side hydronic unit with 2 inverter pumps
- ▶ **VS2X** Source side 2-way ON/OFF valve
- ▶ **VS2MX** Source side 2-way modulating valve
- ▶ **HYGS2** Source side hydronic unit with 2 ON/OFF pumps
- ▶ **HYGS1V** Source side hydronic unit with 1 inverter pump
- ▶ **HYGS2V** Source side hydronic unit with 2 inverter pumps
- ▶ **HYGS1** Source side hydronic unit with 1 ON/OFF pump
- ▶ **VS2** Source side 2-way ON/OFF valve
- ▶ **VS3M** Source side 3-way modulating valve
- ▶ **VS2M** Source side 2-way modulating valve
- ▶ **VS3MX** Source side 3-way modulating valve
- ▶ **HYGR2V** Recovery side hydronic unit with 2 inverter pumps
- ▶ **HYGR1V** Recovery side hydronic unit with 1 inverter pump
- ▶ **IFWX** Water steel mesh strainer
- ▶ **VACSUX** Utility side DHW switching valve
- ▶ **VACSRX** Total recovery side DHW switching valve
- ▶ **VACSR** Total recovery side DHW switching valve
- ▶ **VACSU** Utility side DHW switching valve
- ▶ **MF2** Multi-function phase monitor
- ▶ **SFSTR** Disposal for inrush current reduction
- ▶ **CMSC10** Serial communication module to LonWorks supervisor
- ▶ **CMSC8** Serial communication module to BACnet supervisor
- ▶ **SPCX** Set point compensation with outside temperature probe
- ▶ **PFCP** Power factor correction capacitors (cosφ > 0.9)

Key to symbols:

- Accessories supplied separately.

technical data

Size – WSHN-XEE			82	102	122	162	182	222	262	302	352	402	432	452	502	552	602	702	802
Geothermal (G)																			
▶ Cooling capacity	(1)	kW	39,6	47,2	56,4	63,9	76,4	91,5	107,6	122,3	139	160	177	194	206	226	254	284	312
Total power input	(1)	kW	7,1	8,3	10,4	12,6	14,3	17,3	19,4	22,5	26,3	29,6	33,7	35,1	39,3	42,6	48,3	54,5	60,6
EER (EN 14511:2011)	(1)	-	5,61	5,7	5,44	5,08	5,35	5,3	5,56	5,43	5,31	5,4	5,26	5,53	5,25	5,31	5,25	5,21	5,15
▶ Heating capacity	(2)	kW	26,3	30,6	36,4	43,3	51,8	60,8	73,2	81,8	93,7	108	119	126	138	153	172	199	228
Total power input	(2)	kW	6,1	7,1	8,4	10	11,9	14	16,6	18,7	21,4	24,6	27,2	28,7	31,4	34,6	39	44,9	51,3
COP (EN 14511:2011)	(2)	-	4,3	4,3	4,32	4,31	4,34	4,33	4,43	4,37	4,37	4,41	4,39	4,4	4,41	4,41	4,4	4,44	4,44
Refrigerant circuits		Nr	1	1	1	1	1	1	1	1	1	1	1	1	1	1	1	1	1
No. of Compressors		Nr	2	2	2	2	2	2	2	2	2	2	2	2	2	2	2	2	2
Type of compressors		-	Scroll	Scroll	Scroll	Scroll	Scroll	Scroll	Scroll	Scroll	Scroll	Scroll	Scroll	Scroll	Scroll	Scroll	Scroll	Scroll	Scroll
Standard power supply		V	400/3/50	400/3/50	400/3/50	400/3/50	400/3/50	400/3/50	400/3/50	400/3/50	400/3/50	400/3/50	400/3/50	400/3/50	400/3/50	400/3/50	400/3/50	400/3/50	400/3/50
Standard(S)																			
▶ Cooling capacity	(3)	kW	40,1	46,9	58,1	64,4	76,7	92,3	108	123	141	161	179	191	208	229	256	289	319
Total power input	(3)	kW	6,86	8,2	10,3	12,3	13,9	16,7	18,8	21,8	25,5	28,8	32,8	34,1	38,2	41,5	47	52,6	58
EER (EN 14511:2011)	(3)	-	5,85	5,72	5,64	5,25	5,5	5,52	5,75	5,65	5,51	5,6	5,47	5,6	5,45	5,51	5,44	5,49	5,51
▶ Heating capacity	(4)	kW	35	42,3	48,1	56,1	66,6	79,3	93,8	107	122	139	154	165	179	197	222	252	282
Total power input	(4)	kW	6,23	7,42	8,74	10,3	12,2	14,2	16,8	19,1	22	25	27,6	29,5	32,3	35,3	40,1	46,3	52,7
COP (EN 14511:2011)	(4)	-	5,61	5,7	5,51	5,46	5,47	5,58	5,58	5,59	5,53	5,58	5,56	5,59	5,55	5,58	5,53	5,44	5,35
Refrigerant circuits		Nr	1	1	1	1	1	1	1	1	1	1	1	1	1	1	1	1	1
No. of Compressors		Nr	2	2	2	2	2	2	2	2	2	2	2	2	2	2	2	2	2
Type of compressors		-	Scroll	Scroll	Scroll	Scroll	Scroll	Scroll	Scroll	Scroll	Scroll	Scroll	Scroll	Scroll	Scroll	Scroll	Scroll	Scroll	Scroll
Standard power supply		V	400/3/50	400/3/50	400/3/50	400/3/50	400/3/50	400/3/50	400/3/50	400/3/50	400/3/50	400/3/50	400/3/50	400/3/50	400/3/50	400/3/50	400/3/50	400/3/50	400/3/50
Sound pressure level	(5)	dB(A)	49	49	49	52	53	53	53	53	59	60	62	60	62	62	62	64	65
Size – WSH-XEE																			
Standard(S)																			
▶ Cooling capacity	(3)	kW	38,8	45,6	55,6	63,6	75,6	89,4	98	127	146	165	183	193	216	234	265	295	328
Total power input	(3)	kW	6,58	8,11	9,8	11,4	13,2	15,9	18,5	20,6	23,9	27,8	31	32,6	36,3	40,3	45,1	51,4	58,1
EER (EN 14511:2011)	(3)	-	5,96	5,63	5,65	5,49	5,59	5,45	5,1	5,9	5,85	5,65	5,61	5,59	5,6	5,42	5,45	5,29	5,16
▶ Heating capacity	(4)	kW	34,8	40,8	49,5	57,5	68	81,8	93,5	112	126	143	156	168	186	205	232	263	302
Total power input	(4)	kW	6,61	7,79	9,28	11	12,7	15,5	17,7	20,4	23,2	26,5	29,5	31,4	34,4	38,1	42,7	48,7	55,6
COP (EN 14511:2011)	(4)	-	5,31	5,24	5,31	5,21	5,25	5,16	5,11	5,36	5,31	5,24	5,13	5,16	5,2	5,12	5,14	5,1	5,1
Refrigerant circuits		Nr	1	1	1	1	1	1	1	1	1	1	1	1	1	1	1	1	1
No. of Compressors		Nr	2	2	2	2	2	2	2	2	2	2	2	2	2	2	2	2	2
Type of compressors		-	Scroll	Scroll	Scroll	Scroll	Scroll	Scroll	Scroll	Scroll	Scroll	Scroll	Scroll	Scroll	Scroll	Scroll	Scroll	Scroll	Scroll
Standard power supply		V	400/3/50	400/3/50	400/3/50	400/3/50	400/3/50	400/3/50	400/3/50	400/3/50	400/3/50	400/3/50	400/3/50	400/3/50	400/3/50	400/3/50	400/3/50	400/3/50	400/3/50

Note

- (1) B35/W18 water to the exchanger use side 23/18°C; mix of water and glycol to the source side exchanger 30/35°C. Data refer to operation with a mix of water and propylene glycol at 30% on the source side.
- (2) B0/W35 water to the internal exchanger 30/35°C; water-glycol mix to the external exchanger 0/-3°C. Data refer to operation with a mix of water and propylene glycol at 30% on the source side.
- (3) W35/W18 water to the exchanger use side 23/18°C; water to the exchanger source side 30/35°C.
- (4) W10/W35 water to the exchanger use side 30/35°C; incoming water to the source side exchanger 10°C.
- (5) Sound levels refer to units with full load under nominal test conditions. The sound pressure is measured at 1 m from the external surface of the unit in open field conditions.

По вопросам продаж и поддержки обращайтесь:

Архангельск (8182)63-90-72	Краснодар (861)203-40-90	Рязань (4912)46-61-64
Астана (7172)727-132	Красноярск (391)204-63-61	Самара (846)206-03-16
Белгород (4722)40-23-64	Курск (4712)77-13-04	Санкт-Петербург (812)309-46-40
Брянск (4832)59-03-52	Липецк (4742)52-20-81	Саратов (845)249-38-78
Владивосток (423)249-28-31	Магнитогорск (3519)55-03-13	Смоленск (4812)29-41-54
Волгоград (844)278-03-48	Москва (495)268-04-70	Сочи (862)225-72-31
Вологда (8172)26-41-59	Мурманск (8152)59-64-93	Ставрополь (8652)20-65-13
Воронеж (473)204-51-73	Набережные Челны (8552)20-53-41	Тверь (4822)63-31-35
Екатеринбург (343)384-55-89	Нижний Новгород (831)429-08-12	Томск (3822)98-41-53
Иваново (4932)77-34-06	Новокузнецк (3843)20-46-81	Тула (4872)74-02-29
Ижевск (3412)26-03-58	Новосибирск (383)227-86-73	Тюмень (3452)66-21-18
Казань (843)206-01-48	Орел (4862)44-53-42	Ульяновск (8422)24-23-59
Калининград (4012)72-03-81	Оренбург (3532)37-68-04	Уфа (347)229-48-12
Калуга (4842)92-23-67	Пенза (8412)22-31-16	Челябинск (351)202-03-61
Кемерово (3842)65-04-62	Пермь (342)205-81-47	Череповец (8202)49-02-64
Киров (8332)68-02-04	Ростов-на-Дону (863)308-18-15	Ярославль (4852)69-52-93

Единый адрес: ctv@nt-rt.ru **Веб-сайт:** www.clilive.nt-rt.ru